

Ceramic Single Undersink Replacing Your Filter Cartridge

PLEASE READ CAREFULLY BEFORE ATTEMPTING MAINTENANCE

Before attempting maintenance please ensure you have switched off the feed water to your system.

1. To release pressure from the system, turn on or open your pure water faucet on the benchtop. If no water comes out - the correct valve has been closed.
2. Holding the container upright to avoid spills, use the plastic housing spanner provided to unscrew the filter housing, turning it right to left (see Diagram 2).
3. If you have a Royal Doulton Ultracarb® cartridge as a pre-filter, remove it from the filter housing and under cold running water, scrub it with a clean Scotch-Brite® pad or a kitchen brush (that has not been in contact with food). Remove the other used cartridge and discard. Rinse out the housing and fill each sump with about 1/3 of water. Add about 2 or 3 tablespoons of a disinfectant of your choice and scrub it thoroughly with a brush or sponge. Rinse thoroughly with water.

Note: We recommend replacing your Royal Doulton Ultracarb® cartridge every 6-12 months dependent on water quality and usage.

4. Remove the O-ring from the housing sump and wipe it clean. Lightly lubricate the O-ring with a coating of

silicone grease or olive oil. Put the O-ring back in place and press it down into the groove. (See Diagram 2).

Note: It is common for the O-ring to lift out of the housing and stick to the cap. Make sure the O-ring is seated level in the groove, this step is important to ensure proper filter seal.

Caution: If the O-ring appears damaged, stretched or crimped it should be replaced. Manufacturers recommend replacing the O-ring annually.

5. Remove the new cartridge from the plastic wrapping and insert it into the housing sump making sure that it slips over the housing sump standpipe (see Diagram 3).
6. Screw the cap onto the housing sump and hand-tighten. Do not overtighten. Make sure the cap standpipe aligns over the cartridge (see Diagram 3).

7. Dry the housing and check the connections closely. Slowly turn on the water supply to allow the housing to fill with water. Check for leaks. If no leaks are detected your system is now operational. If leakage occurs recheck all connections. Flush the system with sufficient water to remove any carbon fines before using the water.

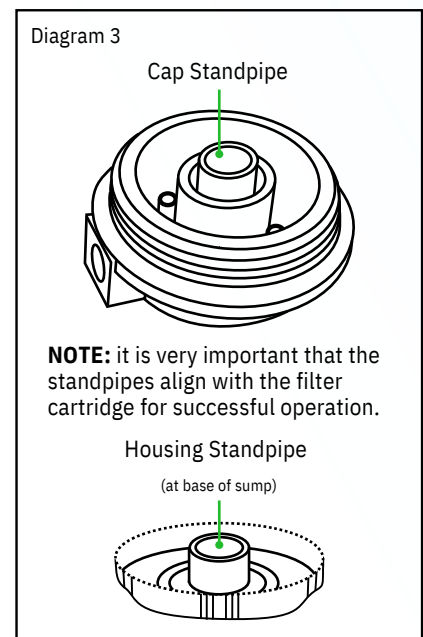
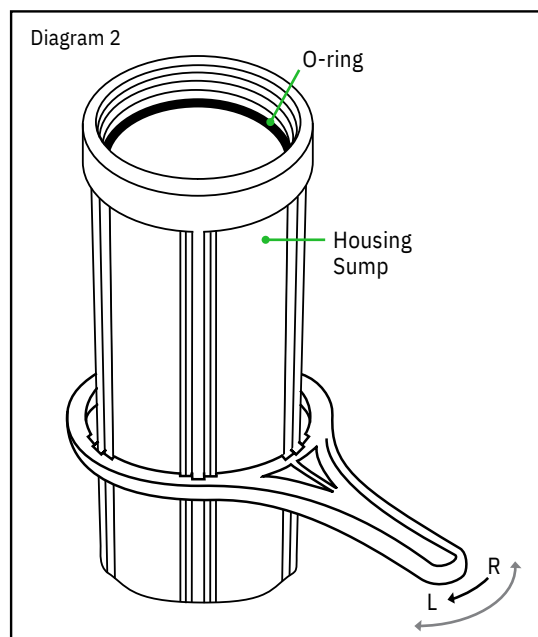
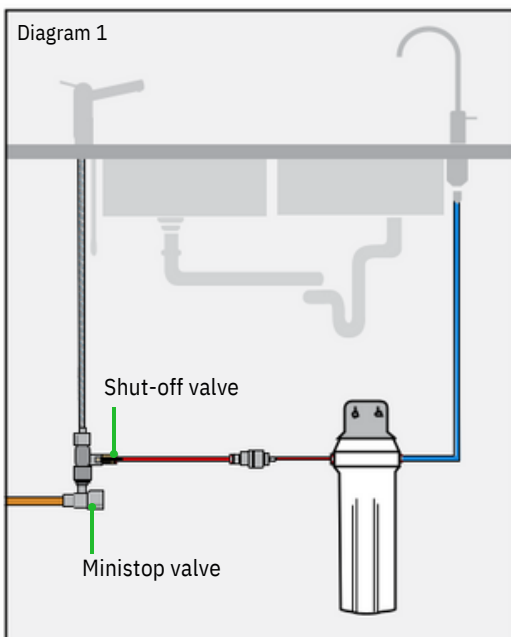

Ceramic Single Undersink

System Assembly Diagram 4

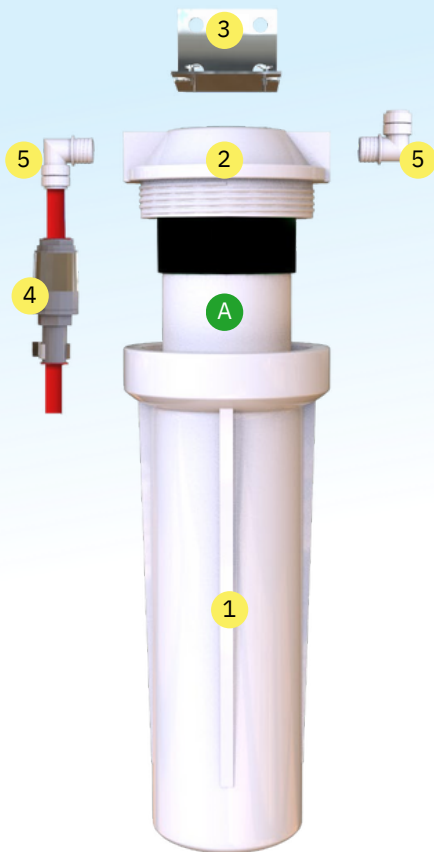

Labelled Components

A	Doulton	Ultracarb®	Filter <small>Made in UK</small>
1	Cartridge Housing Sump		
2	Housing Cap		
3	Stainless Steel Bracket		
4	Pressure Limiting Valve (PLV)		
5	John Guest Elbow (with red clips)		

Available plumbing options

We stock a large range of brass plumbing parts and John Guest Speedfit® fittings for your plumbing requirements. All fittings include a Pressure Limiting Valve.



1/2" Female/Male Tee



3/4" Male Female
Dishwasher

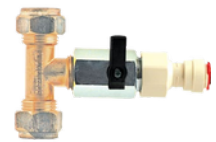

1/2" Male/Male Tee

Important Notes

- Carbon cartridges may contain a small amount of carbon fines (very fine black powder). Hence after installing your new filter cartridge(s), your filter system should be flushed with sufficient water to remove the fines before drinking.
- The filtered water may appear milky for the first few days. This is only oxygen that is released from the carbon. It's safe to drink and it will be clear in a few days.
- Each time you use water from your filtered water tap for drinking or cooking, it is recommended that you run (flush) the tap at least a few seconds prior to using the water. This is particularly important if the water tap is not used daily.
- All replacement cartridges feature a limited service life. Changes in taste, colour and flow of the water being filtered are signals that replacement of the cartridge is due soon or may be immediately necessary.
- Your filter must be protected against freezing. Failure to do so may result in damage to the filter housing and leaks.
- All filtration systems contain other components that have a limited service life. Exhaustion of the service life of those components often cannot be easily detected. Commonly, it is only after leaking or water damage has occurred that one is made aware that the service life has been exhausted. To prevent costly repairs or possible water damage the USA housing manufacturer strongly recommend that the entire housing be replaced every ten years. If your sump has been in use for more than the recommended period, it should be replaced immediately. Be sure to date any new or replacement housing for future reference and indicate the next recommended replacement date.

